

WPA Wall Mounted Axial Fan

Standard features

Casing

The casing manufactured from mild steel hot dip galvanized or high quality epoxy paint in accordance with DIN EN ISO 1461.

The protection guard at the intake side provided as standard. Auto shutter are available as an accessories.

Supply or exhaust configuration of running is available upon request.

Highly efficient impellers

The aerodynamically-shaped impellers made of die-cast aluminium alloy or GRP blades with flexible blade solidities provide optimum efficiency.

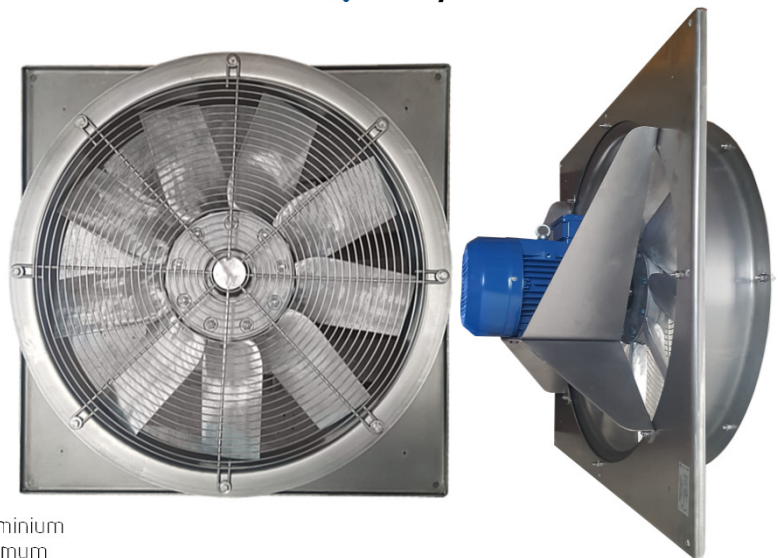

Ordering Code

WPA 630-10/20⁰-4

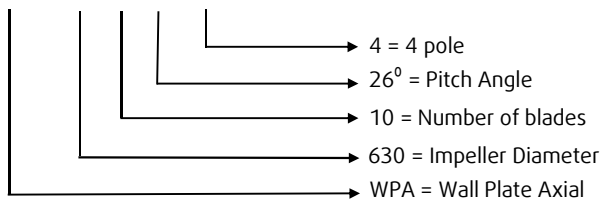

Motor

The IEC standard three-phase motors correspond to the current efficiency classification. IP 55 degree of protection, insulation class F according to EN60034-5.

Available as single and two-speed motors. Speed control of the standard motor is possible using a frequency inverter.

With the Systemair product selector for axial

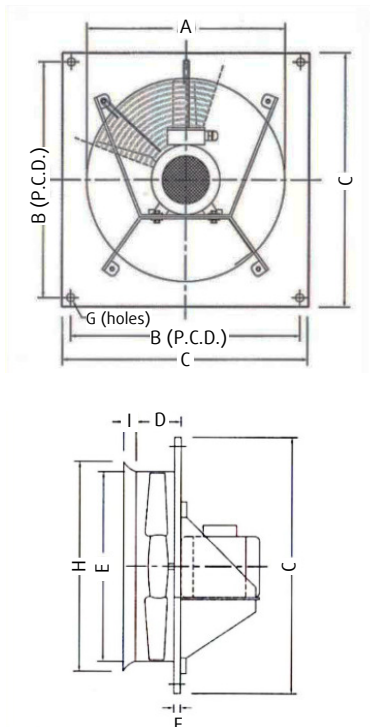

Dimensions

In metric

Model	A	B	C	D	E	F	G	H	I
315	315	390	430	100	315	12	9	360	20
355	355	440	485	100	355	12	9	405	25
400	400	490	540	120	400	12	10	450	25
450	450	535	575	120	450	12	10	495	25
500	500	615	655	120	500	12	14	550	25
560	560	675	725	120	560	15	14	615	30
630	630	755	805	120	630	15	14	685	30
710	710	800	850	120	710	15	14	750	30
800	800	910	970	120	800	15	14	840	30
900	900	1025	1090	150	900	20	14	955	30
1000	1000	1110	1170	180	1000	25	14	1050	30
1120	1120	1245	1310	180	1120	30	16	1170	30
1250	1250	1390	1460	180	1250	30	16	1300	30